

# thor



## Contact Grills

Thor offer a range of contact grills commercially built to meet the demands of busy restaurants and cafes. Machined finished cast iron cooking plates, together with stainless steel construction result in a unit that is robust, heavy duty and reliable. Bottom mounted metal heating elements and moulded cast iron cooking plates allow for faster heat up time and greater heat retention, contributing to efficient operating and cooking results. Thor Contact Grills are available in three sizes and a range of cooking configurations, and all include easy clean pull out grease trays and sturdy head lifting mechanisms. Thor Electric Contact Grills are suitable for counter top operation and are supplied with plug and power lead for easy plug in and set up. Perfect for lower volume restaurants, cafes, mobile catering and other foodservice operations; the contact grill is ideal for grilling sandwiches, paninis, tortillas, burritos, steaks, chicken, fish and any other products that you want to grill quick and easy.

## Product Features

- Stainless steel construction
- Semi embedded elements in cast iron plates provide superior heat distribution and fast recovery
- Heavy duty counter balance handle and hinge system with tension adjustment
- Temperature range: 100° C - 300° C / 220° F - 570° F
- Thermal overload protection
- Thermostat control and indicator light
- Cleaning accessories
- Digital timer

## Contact Grills



# Contact Grills

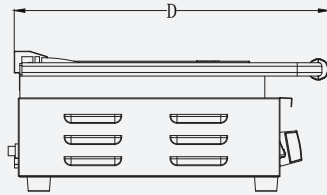
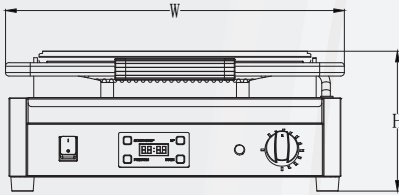
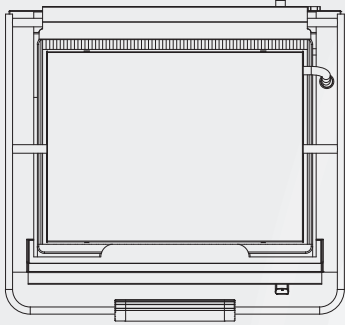

**thor**

Product Code	Capacity/ Cooking Area	Electrical	Cooking Surface	Product Overall Dimensions (mm/inch)		
				Width	Depth	Height
<b>TR02340T-N</b>	375 x 276mm 14.8" x 10.9"	220-240 V, 50 Hz, 2.2 kW, 9.6 A	Flat top Flat bottom	435/17.1	480/18.9	210/8.2
<b>TR02345T-N</b>	375 x 276mm 14.8" x 10.9"	220-240 V, 50 Hz, 2.2 kW, 9.6 A	Rib top Rib bottom	435/17.1	480/18.9	210/8.2
<b>TR02350T-N</b>	375 x 276mm 14.8" x 10.9"	220-240 V, 50 Hz, 2.2 kW, 9.6 A	Rib top Flat bottom	435/17.1	480/18.9	210/8.2

The dimensions given are reference dimensions only. Due to a continuous program of product improvement, Middleby Food Service Equipment reserves the right to make product changes without notice.

This document contains information that is confidential and proprietary to Middleby Food Service Equipment and shall not be reproduced or transferred to other documents or disclosed to others or used for any purpose other than that for which it was obtained without the expressed written consent of Middleby Food Service Equipment.

Middleby Food Service Equipment (Zhuhai) Co., Ltd.  
NO.36,FengShou Road, PingSha Town Zhuhai,  
Guangdong China  
Tel:+86(0756)7267080, 7267067

e: Sales@middleby.com.cn  
www.middleby.com.cn