

thor

Double Fryer



Powerful 3Ltr electric double fryer features separate tanks with independent controls preventing cross-contamination and offers high performance, excellent efficiency. Easy and suitable for counter top operation and is equipped with multiple safety features and is designed to be easily broken down for cleaning.

Product Features

- Removable electrical head with safety switch
- 2x3L capacity
- Non-slip rubber feet
- 2pcs High quality stainless steel baskets
- ON/OFF switch to control main power
- Indicator light to show working
- Thermal cut out device for safe operation
- Capillary thermostat with a temperature range of 60-190°C

Double Fryer



c



Double Fryer

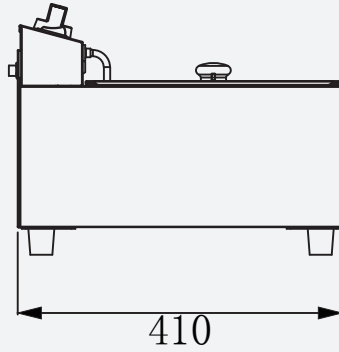
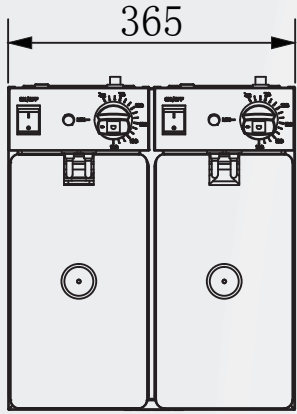
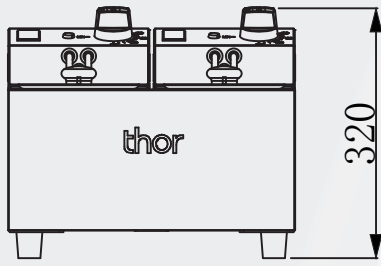

thor

Product Code	Capacity/ Cooking Area	Electrical
TR00410-N	3Ltrs/6Lbs	220-240 V, 50 Hz, 2x2.0 kW 8.7 A

Product Overall Dimensions (mm/inch)

Width	Depth	Height
365/14.3	410/16.1	320/12.5

The dimensions given are reference dimensions only. Due to a continuous program of product improvement, Middleby Food Service Equipment reserves the right to make product changes without notice.

This document contains information that is confidential and proprietary to Middleby Food Service Equipment and shall not be reproduced or transferred to other documents or disclosed to others or used for any purpose other than that for which it was obtained without the expressed written consent of Middleby Food Service Equipment.

Middleby Food Service Equipment (Zhuhai) Co., Ltd.
 NO.36,FengShou Road, PingSha Town Zhuhai,
 Guangdong China
 Tel:+86(0756)7267080, 7267067

e: Sales@middleby.com.cn
www.middleby.com.cn