

thor

A  MIDDLEBY Company

thor

电器产品手册



关注公众微信号
了解更多资讯

这就是创新 这就是美得彼
www.middleby.com.cn

美得彼餐饮设备(上海)有限公司
上海市闵行区沪闵路3888号汉生科技园1号楼105-109室
邮编: 201108
电话: 021-3323 9898



THE MIDDLEBY CORPORATION



THE MIDDLEBY CORPORATION

(NASDAQ : MIDD)

Middleby是一家全球领先的**商业厨房设备、民用厨房设备、食品加工与处理设备的制造商**。三个业务部门拥有超过90个世界知名品牌。

Middleby is one of the world's leading manufacturers of commercial kitchen equipment, civilian kitchen equipment, and food processing equipment. There are more than 90 world famous brands in the three business units.

Middleby 中国聚焦品牌



thor

A MIDDLEBY Company

品牌介绍

Brand Introduction

从2001年推出Thor帕尼尼烧烤架以来，Thor烹饪设备已经发展成为广泛的商业烹饪解决方案。Thor通过将简单的设计与卓越的制造工艺相结合，在商业餐饮设备中实现价值。通过提供高水平的工艺和高质量的部件，我们以卓越的性能和质量支持我们的价值。

美得彼餐饮设备公司致力于为客户提供全面满意的服务。通过提供广泛的燃气和电气台面和独立的烹饪设备，Thor能够为您的商业厨房需求提供一个全面的解决方案。

产品包括:三文治机,电烤炉,链式多士炉,热狗机,电扒炉,加热设备,燃气烤炉,燃气灶,炸炉,面火炉,烤箱等。

Thor了解商业厨房的需求,致力于为您提供最高质量的产品和尽可能低的价格。效率,盈利能力和可靠性是厨房成功的关键,我们保证你不会对Thor失望。

From the launch of the thor panini grill in 2001, thor cooking equipment has developed into a broad range of commercial cooking solutions. Thor delivers value in commercial foodservice equipment by combining simplistic design with superior manufacturing processes. We back up our value with exceptional performance and quality by providing high level workmanship and high quality componentry.

Middleby food service equipment is committed to providing total customer satisfaction. By offering an extensive range of gas and electrical counter-top and freestanding cooking equipment, thor is able to provide a total solution to your commercial kitchen needs.

Contact grills, toaster grills, conveyor toasters, hot dog rollers, griddles, warming equipment, char broilers, hot plates, fryers, salamanders, ovens.

Thor knows the demands of the commercial kitchen and is committed to providing you with the highest quality product and the lowest possible price. Efficiency, profitability and reliability are the key to a successful kitchen and we guarantee you will not be disappointed in thor.



▲ 美得彼餐饮设备（珠海）有限公司



▲ 车间一角



▲ 仓库



▲ 激光切割、数控冲切设备



PRODUCT CONTENTS

美得彼产品目录

1-3 三文治机系列
Panini Grills

4 电扒炉系列
Griddle

5 煎饼机 升降式面火炉
Crepe Maker
Adjustable Salamander Grills

6-7 炸炉系列
Fryer

8 多士炉 煮面机
Conveyor Toaster Pasta Cooker

9 电面火炉 华夫饼机
Salamander Grill Waffle Maker

10 热狗机 保温柜
Hot Dog Roller Pie Warmer

11 滤油车 刀具消毒柜
Oil Filter UVC Sterilizer

12 消毒柜
UVC sterilizer cabinet

单头三文治机 Single Panini grill

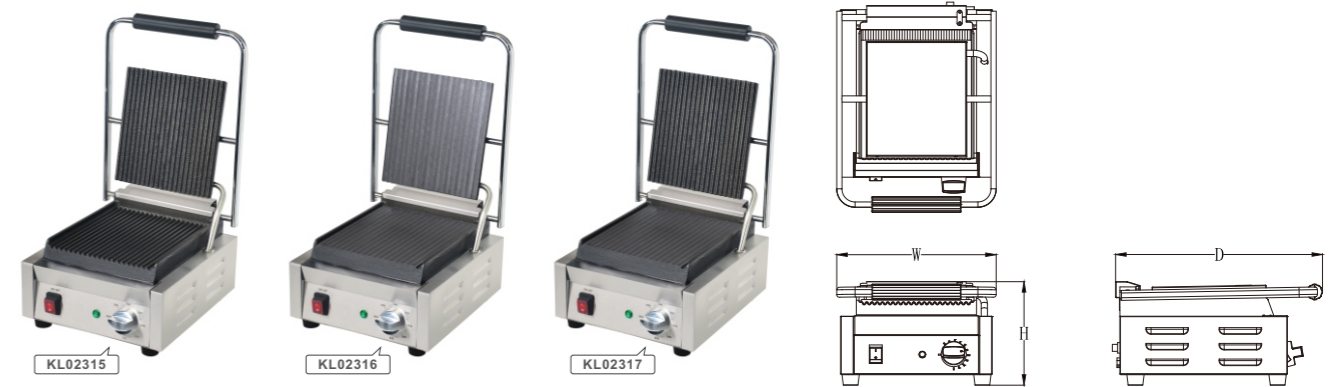

型号Model	烹饪区域 Capacity/Cooking Area	电器参数 Electrical	烹饪面 Cooking surface	净重N(kg)	规格Dimensions(mm)
KL02315	210 x 226mm	220 V, 50 Hz, 1.35 kW, 6.1 A	全坑板 Rib top Rib bottom	14.5	290(W)X395(D)X210(H)
KL02316	210 x 226mm	220 V, 50 Hz, 1.35 kW, 6.1 A	全平板 Flat top Flat bottom	14.2	290(W)X395(D)X210(H)
KL02317	210 x 226mm	220 V, 50 Hz, 1.35 kW, 6.1 A	上坑板 下平板 Rib top Flat bottom	14.5	290(W)X395(D)X210(H)

特点

- 不锈钢结构
- 半嵌入式元素在铸铁板提供优越的热分布和快速恢复
- 重型平衡手柄和铰链系统，张力调节
- 温度范围: 100°C-300°C
- 热过载保护
- 温控器控制和指示灯
- 清洁配件

Features

- Stainless steel construction
- Semi embedded elements in cast iron plates provide superior heat distribution and fast recovery
- Heavy duty counter balance handle and hinge system with tension adjustment
- Temperature range: 100°C-300°C
- Thermal overload protection
- Thermostat control and indicator light
- Cleaning accessories

单头三文治机 Single Panini grill

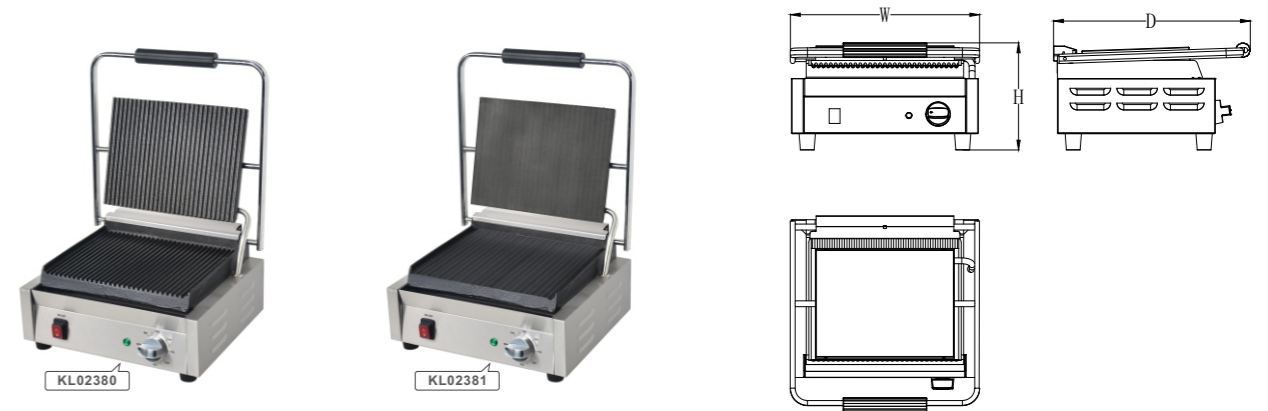

型号Model	烹饪区域 Capacity/Cooking Area	电器参数 Electrical	烹饪面 Cooking surface	净重N(kg)	规格Dimensions(mm)
KL02380	300 x 226mm	220 V, 50 Hz, 2.0 kW, 9.1 A	全坑板 Rib top Rib bottom	19.3	380(W)X395(D)X210(H)
KL02381	300 x 226mm	220 V, 50 Hz, 2.0 kW, 9.1 A	全平板 Flat top Flat bottom	19.6	380(W)X395(D)X210(H)

特点

- 不锈钢结构
- 半嵌入式元素在铸铁板提供优越的热分布和快速恢复
- 重型平衡手柄和铰链系统，张力调节
- 温度范围: 100°C-300°C
- 热过载保护
- 温控器控制和指示灯
- 清洁配件

Features

- Stainless steel construction
- Semi embedded elements in cast iron plates provide superior heat distribution and fast recovery
- Heavy duty counter balance handle and hinge system with tension adjustment
- Temperature range: 100°C-300°C
- Thermal overload protection
- Thermostat control and indicator light
- Cleaning accessories

单头三文治机 Single Panini grill



型号Model	烹饪区域 Capacity/Cooking Area	电器参数 Electrical	烹饪面 Cooking surface	净重N(kg)	规格Dimensions(mm)
KL02340T	375 x 276mm	220 V, 50 Hz, 2.0 kW, 9.1 A	全坑板 Rib top Rib bottom	30.0	435(W)X480(D)X210(H)
KL02345T	375 x 276mm	220 V, 50 Hz, 2.0 kW, 9.1 A	全平板 Flat top Flat bottom	28.5	435(W)X480(D)X210(H)
KL02350T	375 x 276mm	220 V, 50 Hz, 2.0 kW, 9.1 A	上坑板 下平板 Rib top Flat bottom	29.0	435(W)X480(D)X210(H)

特点

- 不锈钢结构
- 半嵌入式元素在铸铁板提供优越的热分布和快速恢复
- 重型平衡手柄和铰链系统，张力调节
- 温度范围: 100°C-300°C
- 热过载保护
- 温控器控制和指示灯
- 清洁配件
- 数字计时器

Features

- Stainless steel construction
- Semi embedded elements in cast iron plates provide superior heat distribution and fast recovery
- Heavy duty counter balance handle and hinge system with tension adjustment
- Temperature range: 100°C-300°C
- Thermal overload protection
- Thermostat control and indicator light
- Cleaning accessories
- Digital timer



双头三文治机 Double Panini grill



型号Model	烹饪区域 Capacity/Cooking Area	电器参数 Electrical	烹饪面 Cooking surface	净重N(kg)	规格Dimensions(mm)
KL02385	210 x 226mm x2	220 V, 50 Hz, 2.7 kW, 12.3 A	全坑板 Rib top Rib bottom	28.0	540(W)X395(D)X210(H)
KL02386	210 x 226mm x2	220 V, 50 Hz, 2.7 kW, 12.3 A	全平板 Flat top Flat bottom	28.5	540(W)X395(D)X210(H)

特点

- 不锈钢结构
- 半嵌入式元素在铸铁板提供优越的热分布和快速恢复
- 重型平衡手柄和铰链系统，张力调节
- 温度范围: 100°C-300°C
- 热过载保护
- 温控器控制和指示灯
- 清洁配件

Features

- Stainless steel construction
- Semi embedded elements in cast iron plates provide superior heat distribution and fast recovery
- Heavy duty counter balance handle and hinge system with tension adjustment
- Temperature range: 100°C-300°C
- Thermal overload protection
- Thermostat control and indicator light
- Cleaning accessories

双头三文治机 Double Panini grill



型号Model	烹饪区域 Capacity/Cooking Area	电器参数 Electrical	烹饪面 Cooking surface	净重N(kg)	规格Dimensions(mm)
KL02385T	210 x 226mm x2	220 V, 50 Hz, 2.7 kW, 12.3 A	全坑板 Rib top Rib bottom	28.0	540(W)X395(D)X210(H)
KL02386T	210 x 226mm x2	220 V, 50 Hz, 2.7 kW, 12.3 A	全平板 Flat top Flat bottom	28.5	540(W)X395(D)X210(H)
KL02387T	210 x 226mm x2	220 V, 50 Hz, 2.7 kW, 12.3 A	上坑板 下平板 Rib top Flat bottom	29.0	540(W)X395(D)X210(H)
KL02388T	210 x 226mm x2	220 V, 50 Hz, 2.7 kW, 12.3 A	左平底右坑板 Half Rib / Half Flat	31.0	540(W)X395(D)X210(H)

特点

- 不锈钢结构
- 半嵌入式元素在铸铁板提供优越的热分布和快速恢复
- 重型平衡手柄和铰链系统，张力调节
- 温度范围: 100°C-300°C
- 热过载保护
- 温控器控制和指示灯
- 清洁配件
- 数字计时器

Features

- Stainless steel construction
- Semi embedded elements in cast iron plates provide superior heat distribution and fast recovery
- Heavy duty counter balance handle and hinge system with tension adjustment
- Temperature range: 100°C-300°C
- Thermal overload protection
- Thermostat control and indicator light
- Cleaning accessories
- Digital timer



电扒炉系列 Griddle

电扒炉 Griddle

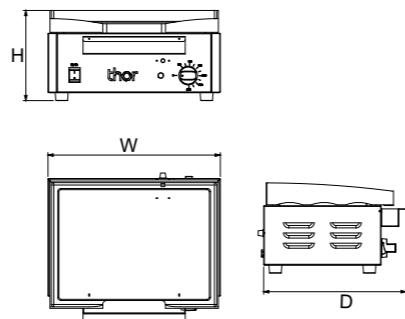

型号Model	烹饪区域Capacity/Cooking Area	电器参数 Electrical	净重N(kg)	规格Dimensions(mm)
PL00470	385x280mm	220 V, 50 Hz, 1.68 kW 7.6 A	16.9	440(W)X365(D)X230(H)
PL00480	385x380mm	220 V, 50 Hz, 2.5 kW 11.4 A	22.2	440(W)X465(D)X230(H)

特点

- 可移动接油盘
- 防滑橡胶脚
- ON/OFF开关控制主电源
- 指示灯显示工作状态
- 热切断装置使操作安全
- 恒温器的温度调节范围为100-300°C

Features

- Removeable drip tray positioned at front of unit
- Non-slip rubber feet
- ON/OFF switch to control main power
- indicator light to show working
- Thermal cut out device for safe operation
- Capillary thermostat with a temperature range of 100-300°C



电扒炉 Griddle

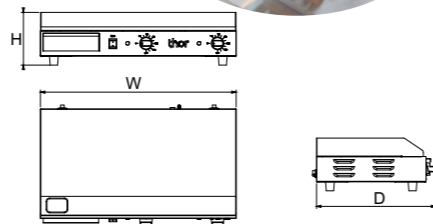

型号Model	烹饪区域Capacity/Cooking Area	电器参数 Electrical	净重N(kg)	规格Dimensions(mm)
PL01680	520x330mm	220 V, 50 Hz, 2.0 kW 9.1 A	21.9	525(W)X450(D)X200(H)
PL01700	735x330mm	220 V, 50 Hz, 2.7 kW 12.3 A	31.0	745(W)X450(D)X200(H)

特点

- 可移动的接油盘
- 防滑橡胶脚
- 筛网刮刀用于清洁油槽
- ON/OFF开关控制主电源
- 指示灯显示工作状态
- 热切断装置使操作安全
- 恒温器的温度调节范围为100-300°C

Features

- Removeable drip tray positioned at front of unit
- Non-slip rubber feet
- Griddle scraper used for clean oil groove
- ON/OFF switch to control main power
- Indicator light to show working
- Thermal cut out device for safe operation
- Capillary thermostat with a temperature range of 100-300°C

Crepe Maker Adjustable Salamander Grills 煎饼机 升降式面火炉

煎饼机 Crepe Maker

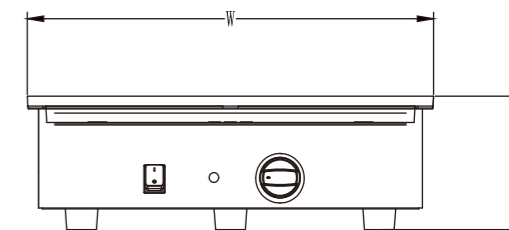
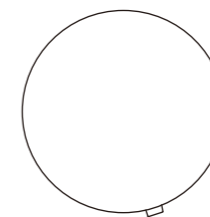

型号Model	烹饪区域Capacity/Cooking Area	电器参数 Electrical	净重N(kg)	规格Dimensions(mm)
JB02390	Ø 410mm	220 V, 50 Hz, 2.7 kW 12.3 A	14.5	410(W)X410(D)X135(H)

特点

- 不锈钢结构
- 表面光滑的重型铸铁板
- 半嵌入式元素在铸铁板提供优越的热量分配和快速回收恒温器控制
- 温度范围: 100°C-300°C
- 热过载保护
- 双重处理
- 防滑支脚
- 配木制刮铲、竹蜻蜓

Features

- Stainless steel construction
- Heavy duty cast iron plates which a smooth machines finished surface
- Semi embedded elements in cast iron plates provide superior heat distribution and fast recovery Thermostat control
- Temperature range: 100°C - 300°C
- Thermal overload protection
- Dual handles
- Non slip feet
- Wooden crepe spreader and spatula



升降式面火炉 Adjustable Salamander Grills

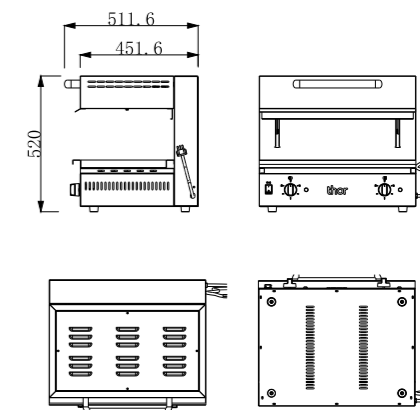

型号Model	烹饪区域Capacity/Cooking Area	电器参数 Electrical	净重N(kg)	规格Dimensions(mm)
KL02550	600*325*195mm	220 V, 50 Hz, 2.7 kW 12.3A	45.0	600(L)X512(W)X528(H)
KL02560	600*325*195mm	380 V, 3P, 50 Hz, 4.4 kW 5.8A/10.1A/5.8A	45.0	600(L)X512(W)X528(H)

特点

- 不锈钢结构
- 双烘焙区
- 双发热管
- 双可调节温控
- 可拆卸的烤架
- 可拆卸的托盘
- 可轻松操作的重量平衡铰链系统
- 防滑脚
- 可选功能: 壁式托架

Features

- Stainless steel construction
- Dual heat zones
- Dual metal heating elements
- Dual variable heat control
- Removable grilling rack
- Removable crumb/grease tray
- Heavy duty counter balance hinge system allowing effortless operation
- Non slip feet
- Optional Features: Wall mount bracket



单缸电炸炉 Single Fryer



型号Model	烹饪区域Capacity/Cooking Area	电器参数 Electrical	净重N(kg)	规格Dimensions(mm)
ZL00400	3Ltrs	220 V, 50 Hz, 1.8 kW 8.2 A	3.8	180(W)X410(D)X320(H)
ZL00405	5Ltrs	220 V, 50 Hz, 2.5 kW 11.4 A	6.6	270(W)X410(D)X320(H)

特点

- 带安全开关的可拆卸电箱头
- 3升/5升容量
- 防滑橡胶脚
- 1个优质不锈钢篮子
- 开关控制主电源
- 指示灯显示工作状态
- 热切断装置使操作安全
- 温控器的温度调节范围为60-190°C

Features

- Removable electrical head with safety switch
- 3L/5L capacity
- Non-slip rubber feet
- 1pcs High quality stainless steel baskets
- ON/OFF switch to control main power
- Indicator light to show working
- Thermal cut out device for safe operation
- Capillary thermostat with a temperature range of 60-190°C

双缸电炸炉 Double Fryer



型号Model	烹饪区域Capacity/Cooking Area	电器参数 Electrical	净重N(kg)	规格Dimensions(mm)
ZL00410	2x3Ltrs	220 V, 50 Hz, 2x1.8 kW 2x8.2 A	6.7	365(W)X410(D)X320(H)
ZL00415	2x5Ltrs	220 V, 50 Hz, 2x2.5 kW 2x11.4 A	10.9	545(W)X410(D)X320(H)

特点

- 带安全开关的可拆卸电箱头
- 2 x 3L / 2 x 5L容量
- 防滑橡胶脚
- 2个优质不锈钢篮子
- 开关控制主电源
- 指示灯显示工作状态
- 热切断装置使操作安全
- 温控器的温度调节范围为60-190°C

Features

- Removable electrical head with safety switch
- 2x3L/2x5L capacity
- Non-slip rubber feet
- 2pcs High quality stainless steel baskets
- ON/OFF switch to control main power
- Indicator light to show working
- Thermal cut out device for safe operation
- Capillary thermostat with a temperature range of 60-190°C

单缸/双缸电炸炉 Single / Double Fryer



型号Model	烹饪区域Capacity/Cooking Area	电器参数 Electrical	净重N(kg)	规格Dimensions(mm)
ZL01845T	5Ltrs	220 V, 50 Hz, 2.5 kW 11.4 A	7.4	280(W)X450(D)X350(H)
ZL01925T	2x5Ltrs	220 V, 50 Hz, 2x2.5 kW 2x11.4 A	13.3	560(W)X450(D)X350(H)

特点

- 热切断装置使操作更安全
- 数字定时器，具有报警功能
- ON/OFF开关控制主电源
- 指示灯显示工作状态
- 独立可拆卸的电箱头
- 温控器的温度调节范围为60-190°C

Features

- Thermal cut out device for safe operation
- Digital timer with alarm function
- ON/OFF switch to control main power
- Indicator light to show working
- Independently controlled detachable head unit
- Adjustable thermostat control(60 to 190°C)

单缸/双缸电炸炉 Single / Double Fryer



型号Model	烹饪区域Capacity/Cooking Area	电器参数 Electrical	净重N(kg)	规格Dimensions(mm)
ZL01860T	8Ltrs	220 V, 50 Hz, 2.7 kW 12.3 A		280(W)X510(D)X440(H)
ZL01865T	8Ltrs	220V/380 V, 3P, 50 Hz, 6 kW 7.9A/13.7A/7.9 A		280(W)X510(D)X440(H)
ZL01940T	2x8Ltrs	220 V, 50 Hz, 2x2.7 kW 2x12.3 A		560(W)X510(D)X440(H)
ZL01950T	2x8Ltrs	220V/380 V, 3P, 50 Hz, 2X6 kW 2X(7.9A)/13.7A/7.9 A		560(W)X510(D)X440(H)

特点

- 放油阀方便排油
- 热切断装置使操作安全
- 数字定时器，具有报警功能
- ON/OFF开关控制主电源
- 指示灯显示工作状态
- 独立可拆卸的电箱头
- 温控器的温度调节范围为60-190°C

Features

- Oil drain valve for easy drainage
- Thermal cut out device for safe operation
- Digital timer with alarm function
- ON/OFF switch to control main power
- Indicator light to show working
- Independently controlled detachable head units
- Adjustable thermostat control(60 to 190°C)



链式多士炉 Conveyor Toaster

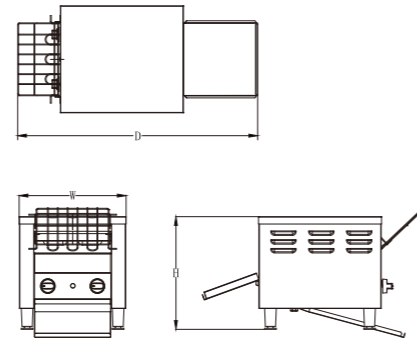

型号Model	烹饪区域Capacity/Cooking Area	电器参数 Electrical	净重N(kg)	规格Dimensions(mm)
DSL02730	260 x 400 x 70mm	220 V, 50 Hz, 2.2 kW 10 A	16.5	370(W)X750(D)X410(H)

特点

- 不锈钢结构
- 可选择前后出料
- 可调加热方式 (单面、双面)
- 可调速度
- 预热模式

Features

- Stainless steel construction
- Optional before and after discharging
- Adjustable heating mode (single, double)
- Adjustable speed
- Preheating mode



煮面机 Pasta Cooker

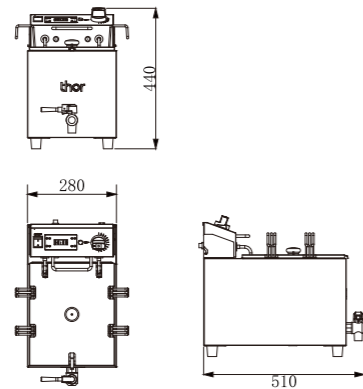

特点

- 不锈钢304汤盆
- 配有放水阀
- 数字定时器，具有报警功能
- 可拆卸电箱头，方便清洁
- ON/OFF开关控制主电源
- 指示灯显示工作状态
- 温控器的温度调节范围为25-100°C

Features

- Stainless steel #304 tank
- Front drain tap
- Digital timer with alarm function
- Detachable head for easy cleaning
- ON/OFF switch to control main power
- Indicator light to show working
- Adjustable thermostat control (25 - 100°C)

型号Model	烹饪区域Capacity/Cooking Area	电器参数 Electrical	净重N(kg)	规格Dimensions(mm)
ZMJ01520	8Ltrs	220 V, 50 Hz, 2.7 kW 12.3 A	10.0	280(W)X510(D)X440(H)

电面火炉 Salamander Grill

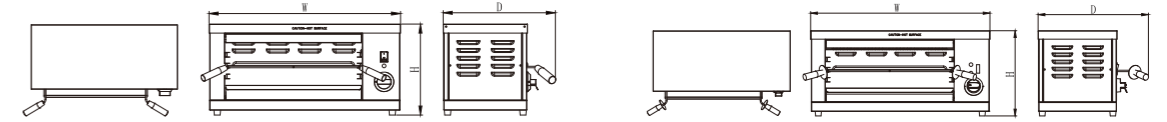

型号Model	烹饪区域Capacity/Cooking Area	电器参数 Electrical	净重N(kg)	规格Dimensions(mm)
KL00540	440x240x105mm	220 V, 50 Hz, 2.5 kW 11.4 A	18.5	679(W)X427(D)X340(H)
KL00550	440x240x105mm	220 V, 50 Hz, 2.5 kW 11.4 A	19.0	679(W)X427(D)X340(H)

特点

- 不锈钢结构
- 3层烤架位置
- 温度范围: 100°C - 300°C
- 易于清除面包屑/垃圾托盘

Features

- Stainless steel construction
- 3 shelf positions
- Temperature range : 100°C - 300°C
- Easy to remove crumb/waste tray



特点

- 不锈钢结构
- 3层烤架位置
- 定时器范围: 0-15分钟
- 转换开关可选择上面或双面烤制
- 易于清除面包屑/垃圾托盘

Features

- Stainless steel construction
- 3 shelf positions
- Timer range: 0-15 minutes
- Toggle switch to use top or both elements
- Easy to remove crumb/waste tray

华夫饼机 Waffle Maker

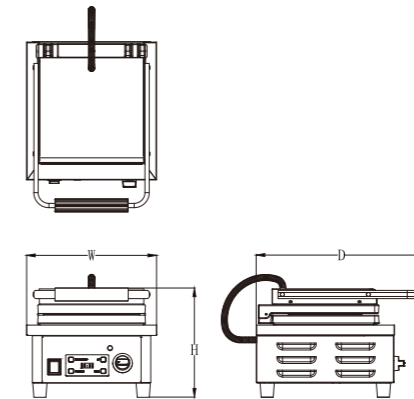

特点

- 不锈钢结构
- 重型铸铁烤板
- 嵌入式发热管快速发热，热分布均匀
- 温控器控制
- 温度范围100°C - 300°C
- 数字计时器

Features

- Stainless steel construction
- Heavy duty cast iron waffle plates
- Embedded elements provide superior heat distribution and fast recovery
- Thermostat control and indicator light
- Temperature range 100°C - 300°C
- Programmable timer

型号Model	烹饪区域Capacity/Cooking Area	电器参数 Electrical	净重N(kg)	规格Dimensions(mm)
KL02310	160x100mm x2	220 V, 50 Hz, 1.85 kW 8.4 A	20.5	395(W)X370(D)X250(H)



热狗机 Hot Dog Roller



型号Model	烹饪区域Capacity/Cooking Area	电器参数 Electrical	净重N(kg)	规格Dimensions(mm)
RGJ01600	11根	220 V, 50 Hz, 1.0 kW 4.5 A	16	430(W)X520(D)X335(H)
RGJ01610	11根	220 V, 50 Hz, 1.2 kW 5.5 A	19.5	595(W)X520(D)X335(H)
RGJ01630	11根	220 V, 50 Hz, 1.5 kW 6.8 A	25.5	895(W)X520(D)X335(H)

特点

- 不锈钢403#材料
- 11根特氟龙涂层滚筒
- 可拆卸接油盘使油收集容易便捷
- 防滑塑胶支撑脚
- 食品级材料, 安全、健康
- 开关控制主电源通断
- 指示灯显示工作状态
- 360° 旋转使加热更均匀
- 低噪音电机



Features

- Stainless steel #430 construction
- 11 Teflon coating rollers
- Removeable drip tray collecting oil easy and convenient
- Non-slip rubber feet
- Food grade material, safe and healthy
- ON/OFF switch to control main power
- Indicator light to show working
- 360 degrees rotate make heating evenly
- Low noise motor

保温柜 Pie Warmer



型号Model	烹饪区域Capacity/Cooking Area	电器参数 Electrical	净重N(kg)	规格Dimensions(mm)
BWG03170	428 x 275 mm x 3	220 V, 50 Hz, 300W 1.4A	14.5	470(W)X365(D)X435(H)
BWG03180	708 x 275 mm x 3	220 V, 50 Hz, 600W 2.7A	21	745(W)X365(D)X435(H)

特点

- 恒温器控制
- 温度范围: 30°C-90°C
- 容量: 30/60个馅饼
- 金属元素
- 不锈钢通风元件护罩
- 玻璃推拉门
- 3 x 机架-易于拆卸清洗
- 可移动的玻璃, 架子和面包屑托盘易于清洁

Features

- Thermostat control
- Temperature range: 30°C-90°C
- Capacity: 30 pies/60 pies
- Metal element
- Stainless steel vented element guard
- Glass sliding door
- 3 x racks - easily removed for cleaning
- Removable glass, shelves and crumb trays for easy cleaning



滤油车 Oil Filter

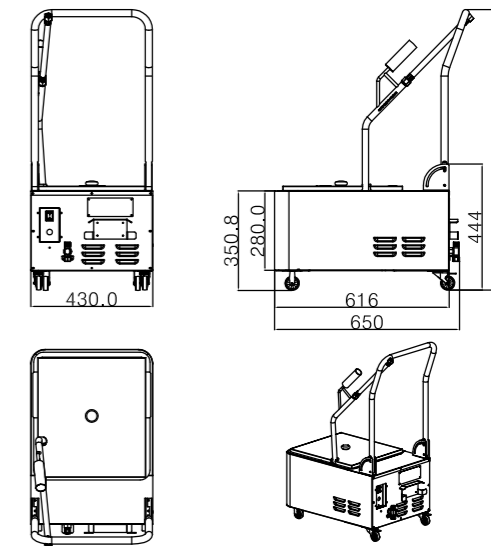

型号Model	油缸容量Capacity of tank	电器参数 Electrical	净重N(kg)	规格Dimensions(mm)
LYC04000	23L	220 V, 50 Hz, 650W 3A	32	430(W)X650(D)X990(H)

特点

- 不锈钢#430结构与#201油箱
- 高效过滤系统
- 每分钟过滤12-15L油
- 可拆卸不锈钢滤网和滤纸支架
- 电机过热保护系统
- 两个制动转轮和两个固定轮
- 标准电源线和插头与存储支架
- 电源开关
- 不锈钢油泵
- 后方的清洁用排污口
- 不锈钢盖和过滤篮

Features

- Stainless steel #430 construction with #201 oil tank
- Efficient filtering system
- Filters 12-15L oil per minute
- Removable stainless steel filter screen and filter paper bracket
- Motor overheat protection system
- Two braked swivel castors and Two fixed castors
- Standard Power cord and plug with storage bracket
- On/off switch
- Stainless steel return pump
- Rear Drain tap for cleaning
- Stainless steel cover and filter basket

刀具消毒柜 UVC sterilizer



型号Model	烹饪区域Capacity/Cooking Area	电器参数 Electrical	净重N(kg)	规格Dimensions(mm)
XDG01400	15	220 V, 50 Hz, 20W 0.1A	7.5	645(W)X240(D)X725(H)

特点

- 120分钟计时器
- 可拆卸的15刀架支架
- 防碎的可封闭的门
- 紫外线

Features

- 120 min timer
- Removable 15 knife rack holder
- Shatterproof lockable door
- UV light



XDG01430

特点

- 数字计时器控制
- 6套可调导轨
- 2个紫外线灯
- 易于更换碳过滤棉
- 4个脚轮(2个制动)

Features

- Digital Timer Control
- 6 sets of adjustable runners
- 2 x UVC lamps
- Easy to replace carbon filter
- 4 castors (2 x braked)



XDG01420

特点

- 数字定时器控制
- 4套可调导轨
- 2个紫外线灯
- 易于更换碳过滤棉
- 2个可调脚和2个固定轮

Features

- Digital Timer Control
- 4 sets of adjustable runners
- 2 x UVC lamps
- Easy to replace carbon filter
- 2 adjustable feet and 2 fixed wheels



XDG01410

特点

- 数字定时器控制
- 2套可调导轨
- 1个紫外线灯
- 易于更换碳过滤棉
- 4个固定脚

Features

- Digital Timer Control
- 2 sets of adjustable runners
- 1 x UVC lamp
- Easy to replace carbon filter
- 4 fixed feet

型号Model	消毒区域Capacity/Cooking Area	电器参数 Electrical	净重N(kg)	规格Dimensions(mm)
XDG01410	376 x 407 x 255mm	220 V, 50 Hz, 15 W 0.07 A	21.0	430(W)X480(D)X418(H)
XDG01420	376 x 407 x 680mm	220 V, 50 Hz, 25 W 0.11 A	34.5	430(W)X480(D)X852.6(H)
XDG01430	546 x 529 x 1627mm	220 V, 50 Hz, 50 W 0.22 A	84.2	600(W)X600(D)X1870.3(H)



.....多场景下使用.....